



FRIENDS EXHIBITION 2024 – TERMS & CONDITIONS OF ENTRY

Royal West of England Academy (RWA)
Queens Road, Bristol BS8 1PX Tel: 0117 973 5129
Tuesday - Sunday 10am – 5pm
29 March – 28 April

Please read these Conditions of Entry carefully; by completing the Exhibition Entry Form you will be accepting the conditions set out below. The Friends reserve the right to refuse work not complying with the conditions below.

	KEY DATES:		
Opening of online entry form:	Monday	29 January 2024	
Closure of online entry and payment:	Friday	1 March 2024	5pm
Handing in of work at RWA:	Sunday	24 March	11.00am – 2.00pm
Selection process:	Monday	25 March	10.30am – 12.30pm
*Collection of non-selected work:	Monday	25 March	2.30pm – 4.30pm
Private View at RWA:	Thursday	28 March	5.30pm – 7.30pm
Exhibition opens	Friday	29 March	10am
Exhibition closes	Sunday	28 April	5pm
*Collection of unsold works at RWA:	Tuesday	30 April	2pm – 5pm
Collection of sold works at RWA:	Tuesday	30 April	2pm – 5pm

1. All works submitted must be from artists who are Friends of the RWA.
2. All submissions must be made online, please contact friends.rwa1@gmail.com if you do not have access to a computer.
3. Entry fees are £12.00 per work entered (non-returnable).
4. You can submit up to four original works at a minimum selling price of £100 per work (including RWA commission). All work must be for sale.
5. All works must have been made by the artist submitting them.
6. Online entry is open on the 29 January 2024. Please date all payments from 29 January 2024 onwards! Entries are only accepted once the submission fee has been paid in full. Save a copy of the form.
7. All exhibition entry forms and payments must be submitted by the deadline of 5pm Fri 1 March 2024.
8. Images: please provide a jpg image of each artwork. Image must be less than 1MB in size and be labelled with artwork title and artist. Contact friends.rwa1@gmail.com if you need help. All images must be of the original piece. Please make a note of the images and titles submitted.

9. The RWA may, without any breach of copyright, take photographs or other images of any item selected and exhibited at the exhibition and use the same for its own records, advertising the Friends' activities and for use on the RWA website.
10. Completing the Exhibition Entry Form permits the Friends to hold the personal details submitted by the artist on file and be used for the Friends' activities. The Friends will not share this information with any third party.
11. All details submitted (title, price and image) cannot be changed after 1 March.
12. All works will be subject to selection; selected works will be hung subject to available space – the organiser's decision will be final. All work is judged anonymously and without favour.
13. There will be a panel of three selectors which will include RWA Academicians whose decision is final.
14. The Friends of the RWA do not insure the works before, during or after the Exhibition and disclaim all liability for loss or damage to the works; all artists should arrange for their own insurance if required.
15. The name and date on the Exhibition Entry form means that the artist expressly accepts all the conditions and rules set out herein and agrees to be bound by them.
16. We accept **2D artworks MAX SIZE 60cm along any side, including frame. We have got plenty of space identified specifically for smaller pieces. 3D works MAX SIZE base 30cm along any side, including supports, and height 50cm. See guidance at the end.**
17. The selected artwork must be available for the duration of the exhibition at the RWA.
18. Selected artworks will be for sale on the RWA website and cannot be listed for sale elsewhere for the duration of the show.
19. Watercolours, pastels and drawings must be glazed, using picture glass only.
20. All pictures must be ready to hang, in strong frames with secure 'D' rings and CORD. Exact measurement from top to 'D' ring is 5cm. NO WIRE PLEASE.
21. Unframed oils or acrylics on canvas will be accepted if prepared ready to hang as above.
22. No works will be accepted which have been copied from any paintings, books, postcards, calendars, photographs or other published work or copyright material.
23. We do not accept giclée prints, copies or reproductions or work in unframed glass (held by clips) or Perspex, or with an insecure frame.
24. Please do not submit works previously hung in the Friends' Exhibition.
25. No work by deceased artists.
26. It is expected that all exhibitors will volunteer to steward and/or help.
27. Commission will be charged at 42% (incl. VAT). Net proceeds will be remitted after the Exhibition. The RWA aims to make payment to the artist within 28 days of the end of the exhibition.
28. Collection of unsold work should be on the date specified. If you are not able to collect the work in person, please arrange for a courier or representative to collect it for you. All works will be handed over against a receipt; any works collected by a third party must bring the appropriate authorisation.
29. Unselected work MUST be collected on Monday 25 March 2024 between 2.30 - 4.30pm.
30. Works exhibited and not sold MUST be collected on Tuesday 30 April 2024 between 2pm - 5pm.
31. *A handling charge of £10 per item will be levied on works not collected on time.
32. Sold works MUST be collected on Tuesday 30 April 2024 between 2pm - 5pm.
33. If a buyer is unable to collect the work on Tuesday 30 April, the artist will be asked to collect the work and arrange with the buyer for delivery after the exhibition has closed.
34. **Each work must be clearly labelled on the back with Name, Work Title, Medium, Price and FRWA Membership Number.**
35. **Another white label must be firmly attached with string to hang approximately 6" (15cm) over the front of the picture, showing Name, Work Title, Medium, Price and FRWA Membership Number.**

36. A similar label should also be attached to 3D work.

37. Please cover any additional fixings with masking tape.

38. Works should be delivered unwrapped, there will be space to unwrap your work on delivery. Packaging must then be removed by the artist.

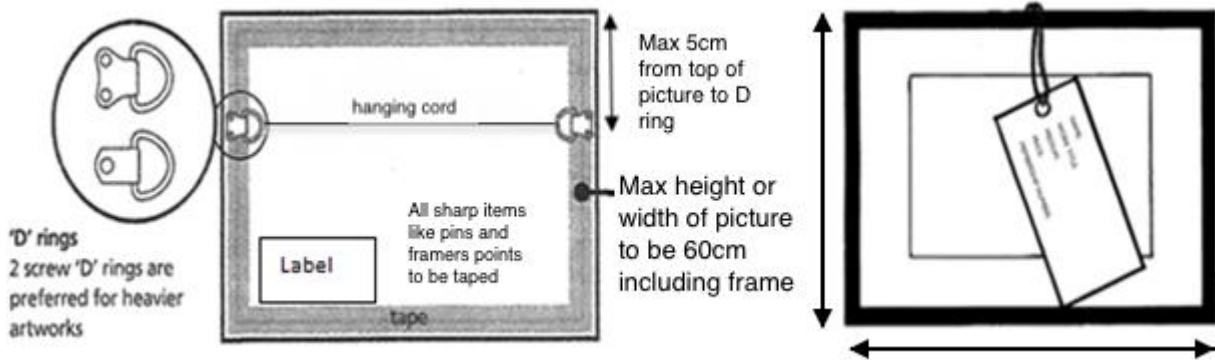

Maximum dimensions for 3D work

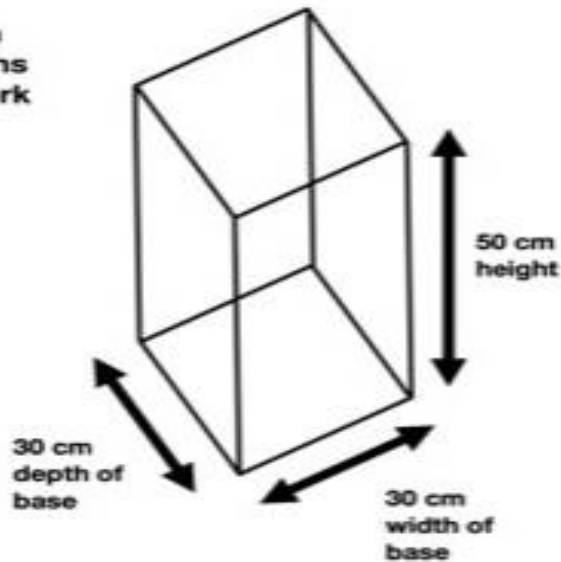

Online Transfer Payment: HSBC Bank Account No: 91220217. Sort Code: 40-14-09. Please use reference in the following format: Membership number and "FEXH" – e.g.: 1234FEXH

If unable to pay online, please submit entry form online and contact the RWA in person or by phone to pay with a card. RWA, Queens Road, Clifton, Bristol, BS8 1PX Tel 0117 973 5129. Unfortunately, we cannot accept cheque or cash payments on this occasion.